



PRODUCT INFORMATION

# Pipelife Gas-Stop

Enhanced safety for service lines



Product information for Pipelife Gas-Stop. Edition 01.00/03  
All technical information is subject to changes due to  
modifications of the product in the course of technical  
improvement. Our General Terms of Contract and Delivery apply  
to contracts.

**Pipelife Austria GmbH & Co KG**  
IZ-NÖ Süd, Straße 1, Objekt 27  
A-2355 Wiener Neudorf - Austria  
Tel.: +43 (0) 2236 6702-281 or 680  
Fax: +43 (0) 2236 6702-264 or 670  
E-mail: [gasstop@pipelife.at](mailto:gasstop@pipelife.at)  
Internet: [www.pipelife.at](http://www.pipelife.at)

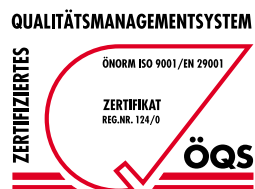

---

# Table of Contents

	Page
Pipelife Gas-Stop System Description .....	2
Product Overview .....	3
Function .....	4
Dimensions, Materials .....	5
Quality Assurance, Certification .....	6
Technical Data .....	7 – 16
Operation pressure range 15–100mbar .....	8
Operating pressure range 25–100mbar .....	9
Operating pressure range 150mbar–5bar .....	10–11
Operating pressure range 1–5bar .....	12–13
Operating pressure range 300mbar–5bar .....	14–16
Installation Instructions .....	17–20



Gaz de France \*



\*certified and recommended for application

# Pipelife Gas-Stop

## Self-activating, high-speed shut-off valve for service lines.

One common cause of gas leaks is damage to service lines which occurs during underground construction work.

Manipulation or improper handling within the building (in the area up to the shut-off valve or the pressure regulator) have also led to accidents in the past.

Pipelife Gas-Stop was developed together with gas supply companies and is designed to prevent such leaks.

In the event of damage or improper handling in the line system between the main line and the pressure regulator, the Pipelife Gas-Stop installed in the system automatically closes in a fraction of a second immediately upon exceeding of the pre-set flow value.

For example, the flow of gas will be shut-off in the event that the gas supply line suffers as little as 5 –15% cross-sectional damage.

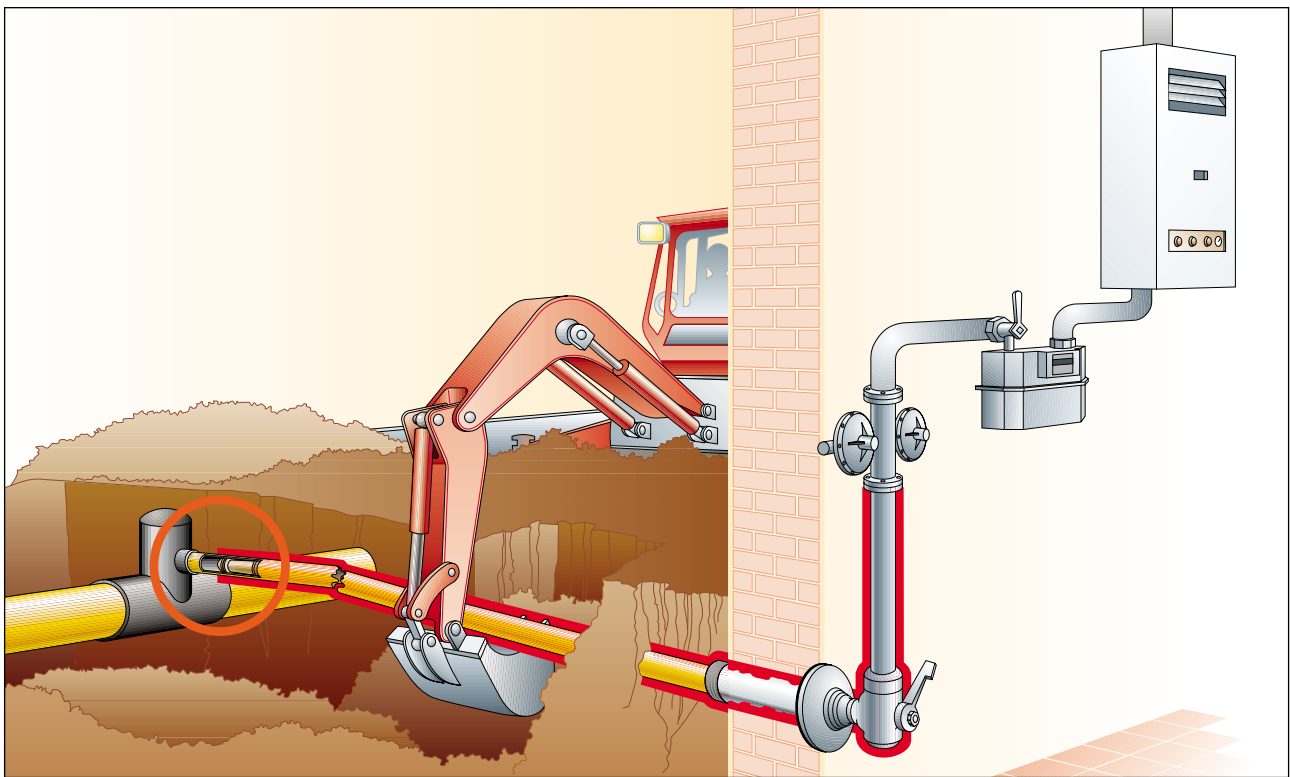

*The protection of the Pipelife Gas-Stop extends from the main line up to the main shut-off mechanism or pressure regulator in the building.*

Pipelife Gas-Stop is now in use by more than one hundred gas supply companies in Europe with excellent success. In hundreds of instances, gas leaks have been prevented after excavation work or improper handling.

A summary of the experience gathered by the users has highlighted three key advantages of the Pipelife Gas-Stop safety unit:

- **Added safety due to the prevention of gas leaks resulting from excavation work or improper handling in the area up to the pressure regulator.**
- **No leakage of gas from the time the leak is reported until the repair personnel arrive on the scene, which eliminates the risks for all parties involved.**
- **Repairing gas leaks often causes significant disturbances for the public, which is detrimental to the marketing activities of gas supply companies. Repair of damage to lines fitted with Pipelife Gas-Stop units does not require repair activities which disturb the public.**

## Product Summary / Article Designation

Operating Pressure Range	Line Dimension				
	Ø20/DN15	Ø25/DN20	Ø32/DN25	Ø50/DN40	Ø63/DN50
15 – 100mbar				GS50/15 GSA50/15	GS63/15 GSA63/15
25 – 100mbar			GS32/25 GSA32/25	GS50/25 GSA50/25	GS63/25 GSA63/25
150mbar – 5bar		GS25/150 GSA25/150	GS32/150 GSA32/150	GS50/150 GSA50/150	GS63/150 GSA63/150
1 – 5bar	GS20/1 GSA20/1*	GS25/1* GSA25/1*	GS32/1 GSA32/1	GS50/1** GSA50/1**	GS63/1 GSA63/1
300mbar – 5bar				GS50/300* GSA50/300*	GS63/300 GSA63/300

\* Available on request \*\* Available as of March 2000

**Note:** Pipelife Gas-Stop is suitable for operating pressures up to 10bar. More detailed information is available upon request.

### Explanation of the article designation using GSA 32/150 and GS 32/150 as examples:

GS.....Pipelife Gas-Stop without adapter

GSA.....Pipelife Gas-Stop with adapter

32.....d<sub>a</sub> service line

150.....Minimum functional pressure in mbar or bar (yellow series)

### Type GS

For installation in the outlet of tapping saddles with suitable (compatible) internal diameter.

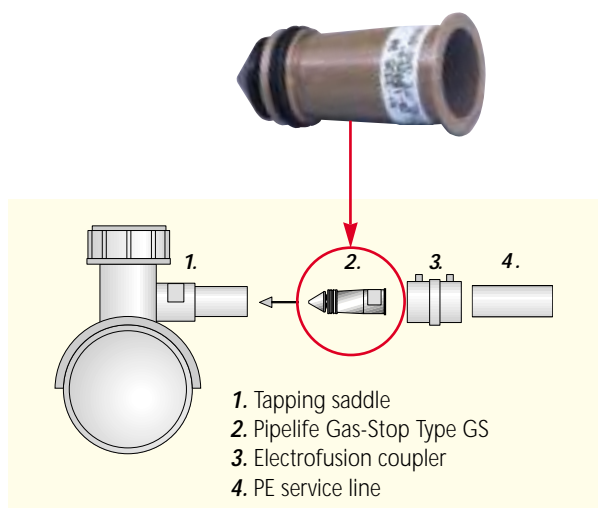

### Type GSA

Integrated in a pipe section (adapter) made of PE.

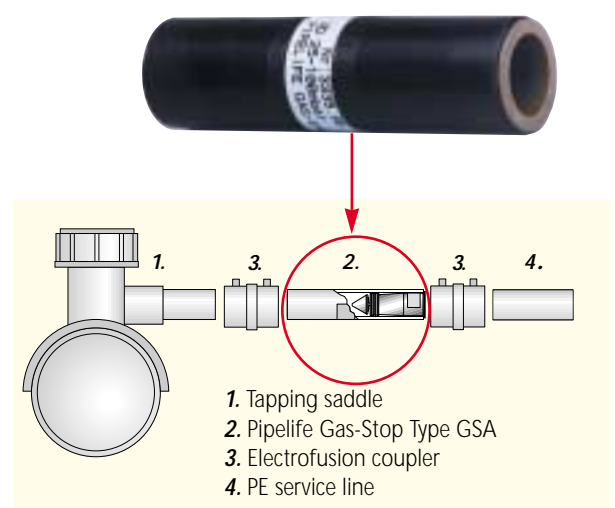

## Dimensions

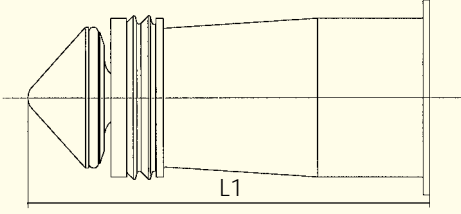
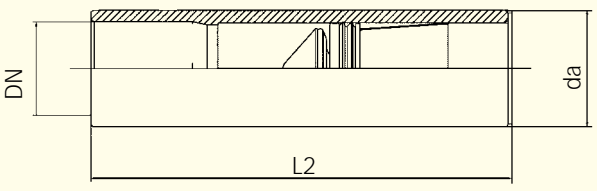
Type GS		Type GSA			
					
Type	L1	Type	DN	da	L2
GS20	42,5 +0,3	GS20	15	20	100*
GS25	50,0 +0,3	GS25	20	25	110
GS32	63,5 +0,3	GS32	25	32	115*
GS32/1	64,5 +0,3	GS50	40	50	130
GS50	73,1 +0,3	GS63	50	63	145
GS63	94,7 +0,3				
GS63/300	104,6 +0,3				
GS63/1	102,0 +0,3				

\*Gaz de France –150mm

(in mm)

(in mm)

## Materials

Adapter (Type GSA): Polyethylene PE 80      Closure element: Polyphenylsulfide - PPS      Spring: Stainless steel, mat. 1.4539

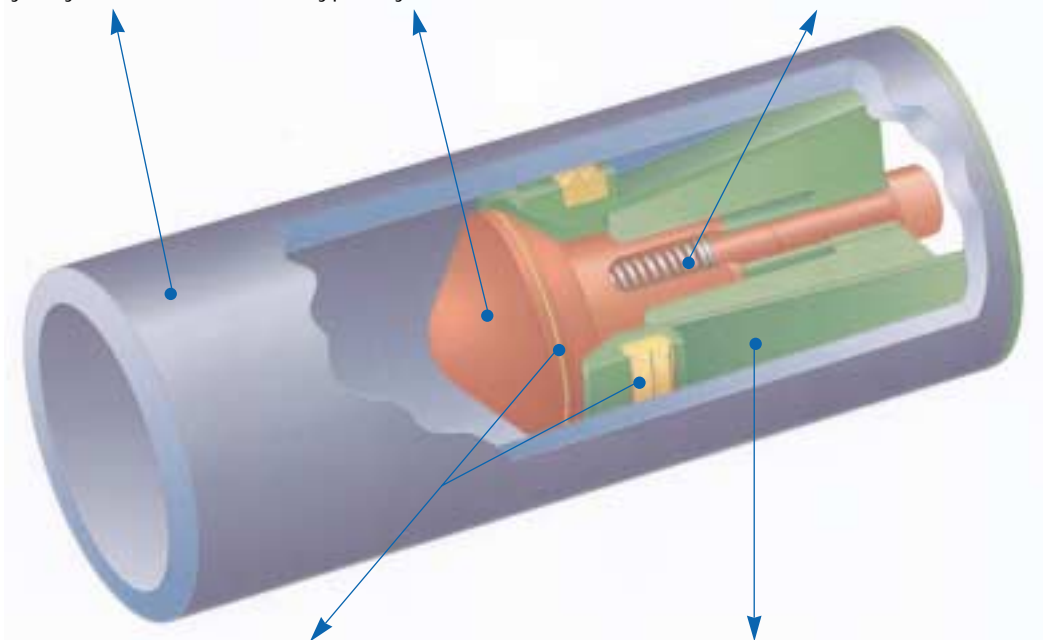

O-ring or profile ring:  
Nitrile-Butadiene-Rubber NBR

Flow body:  
Polyphenylsulfide - PPS

## Quality Assurance

Pipeline Gas-Stop are safety products which must meet the highest standards for operational life and safety. Consequently, the products are subject to comprehensive quality assurance inspections. These inspections cover both individual components and the final product.

One of the most important inspection steps is the functional test: using a fully-automated testing unit, the shut-off flow and seal of **every single Pipelife Gas-Stop** is evaluated and recorded by state-of-the-art measurement equipment.

Positive inspection results are documented on the product by assigning a serial number. All of

the inspection results for the individual components are assigned to this serial number, so that complete traceability is ensured.



## Certified in:

	Germany	Austria	Switzerland	France	Czech Republic	Hungary	Poland	Italy
	DVGW -4bar	ÖVGW -4bar	SVGW -5bar	Gaz de France -4bar	Gas -4bar	Dunagaz -4bar	INGN -4bar	Italgas -5bar
GS50/15		◆	◆		◆	◆	◆	◆
GSA50/15								
GS63/15		◆	◆		◆	◆	◆	◆
GSA63/15								
GS32/25	◆	◆	◆		◆	◆	◆	◆
GSA32/25								
GS50/25	◆	◆	◆		◆	◆	◆	◆
GSA50/25								
GS63/25	◆	◆	◆		◆	◆	◆	◆
GSA63/25								
GS25/150		◆	◆		◆	◆	◆	
GSA25/150								
GS32/150	◆	◆	◆		◆	◆	◆	◆
GSA32/150								
GS50/150	◆	◆	◆		◆	◆	◆	◆
GSA50/150								
GS63/150	◆	◆	◆		◆	◆	◆	◆
GSA63/150								
GS20/1	◆**	◆**		◆*				◆
GSA20/1								
GS32/1	◆**	◆**		◆**				◆
GSA32/1								
GS50/1	◆**	◆**						◆**
GSA50/1								
GS63/1	◆**	◆**						◆
GSA63/1								
GSA63/300	◆**	◆**				◆**		◆**

\* in combination with different tapping saddles

\*\* in preparation

# General Explanation of Operating Ranges and Flow Data

## Nominal Flow:

All flow values in the following tables and flow diagrams are for natural gas  $\rho_n = 0,74\text{kg/m}^3$

**Note:** The nominal flow is dependent on the network's operating pressure. When determining the Pipelife Gas-Stop type (nominal diameter), the minimum network pressure should be taken as a basis.

**Example:** Network pressure  $p_{\max}$  4bar,  $p_{\min}$  2bar maximum nominal flow of type GS25/150 and GSA25/150 at 2bar is  $16\text{m}^3/\text{h}$  [SC]

## Abbreviations:

- $V_n$  nominal flow
- $V_s$  shut-off flow
- $V_{s\max}$  max. shut-off flow
- $V_{s\min}$  min. shut-off flow
- [SC] standard conditions (barometric pressure of 1013.25 mbar, gas temperature of 0°C)
- $\Delta p$  differential pressure
- $p_e$  Pipelife Gas-Stop input pressure

## Shut-off flow:

As is shown in the diagrams, Pipelife Gas-Stop units shut-off in a pre-determined range (= shut-off range). The minimum and maximum shut-off values are for installation according to the following diagram.

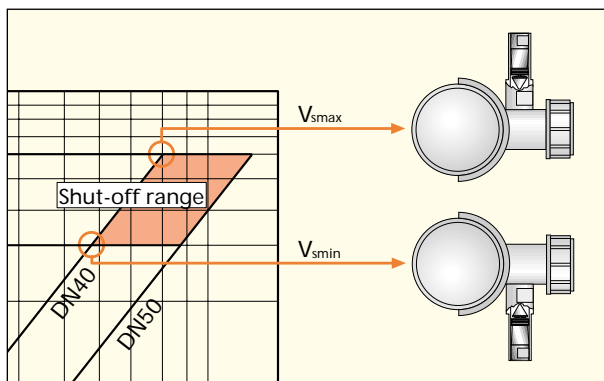

## Shut-off Seal:

Maximum leakage rates as per DVGW-VP 305 are valid for Pipelife Gas-Stop at operating pressure ranges of  $\geq 150\text{mbar}$ .

## Flow and Shut-off Values for other Gases:

Flow value for natural gas as per flow diagram x correction factor = flow value for other gas.

**Calculation for the Correction Factor:**

$$f = \sqrt{\frac{0.74}{\rho_n}}$$

$f$  = correction factor  
 $\rho_n$  = standard density of other gas in  $\text{kg/m}^3$  at 1013,25 mbar, 0°C

**Example:**

$V_n$  natural gas H =  $10\text{m}^3/\text{h}$ [SC] - ? flow value for propane ( $\rho_n = 2.02 \text{ kg/m}^3$ )

$$10 \cdot \sqrt{\frac{0.74}{2.02}} = \underline{6\text{m}^3/\text{h}[SC] \text{ propane}}$$



## Operating Pressure Range 15 – 100mbar

GS50/15, GSA50/15 – Ø 50/DN 40  
 GS63/15, GSA63/15 – Ø 63/DN 50

### Flow Data

Meter Size	Pipelife Gas Stop Type	DN	$V_n$ m <sup>3</sup> /h at $p_e$ 15-100mbar
G2,5 – G10	GS 50/15 GSA 50/15	40	16
G2,5 – G16	GS 63/15 GSA 63/15	50	25

Max. overflow volume for all types:  
 Pressure range 15–25mbar .... max. 110l/h  
 Pressure range 25–100mbar ...max. 30l/h  
 each for air under standard conditions

☞ The nominal flow values for Pipelife Gas-Stop 15–100mbar are determined according to the meter sizes. When the meter size of a household unit is set, this determines the dimension (nominal diameter) of the Pipelife Gas-Stop.

The maximum permissible installation range for these types is shown in the adjacent diagram

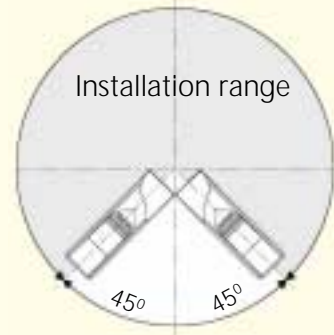

### Flow Diagram

**Example:** → ●  
 Pipelife Gas-Stop  
 GS50/15  
 $V_n = 10\text{m}^3/\text{h}[\text{SC}]$   
 $\Delta p = 0.4\text{mbar}$

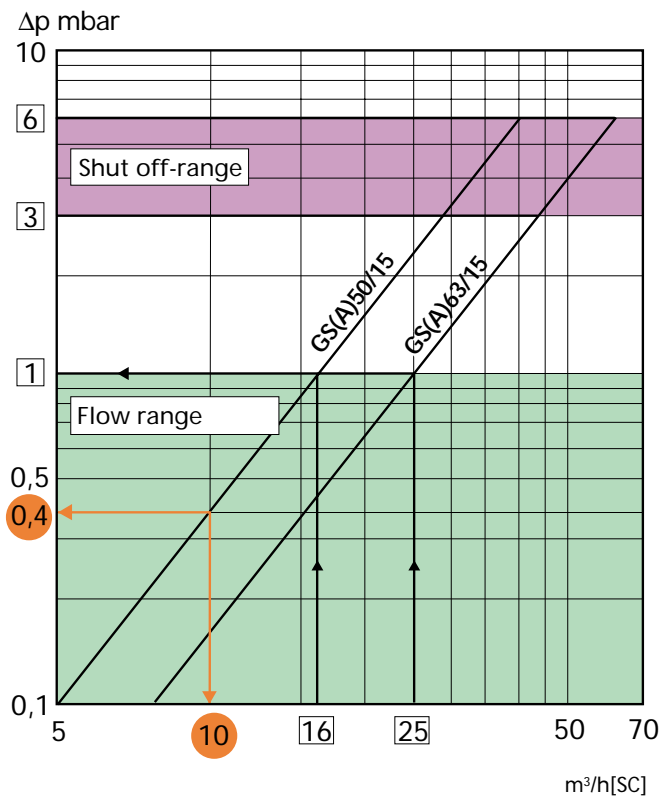



## Operating Pressure Range 25 – 100mbar

GS32/25, GSA32/25 - Ø 32/DN 25

GS50/25, GSA50/25 - Ø 50/DN 40

GS63/25, GSA63/25 - Ø 63/DN 50

## Flow Data

Meter size	Pipelife Gas-Stop Type	DN	$V_n$ m <sup>3</sup> /h at $p_e$ 25–100mbar
G2,5 – G6	GS 32/25 GSA 32/25	25	10
G2,5 – G16	GS 50/25 GSA 50/25	40	25
G2,5 – G25	GS 63/25 GSA 63/25	50	40

Max. overflow volume for all types: 30l/h air [SC]

➡ The nominal flow values for Pipelife Gas-Stop 25–100mbar are determined according to the meter sizes. When the meter size of a household unit is set, this determines the dimension (nominal diameter) of the Pipelife Gas-Stop.

25 - 100 mbar

## Flow Diagram

Example: → ●

Pipelife Gas-Stop

GSA32/25

$V_n = 4 \text{ m}^3/\text{h}[\text{SC}]$

$\Delta p = 0,4 \text{ mbar}$

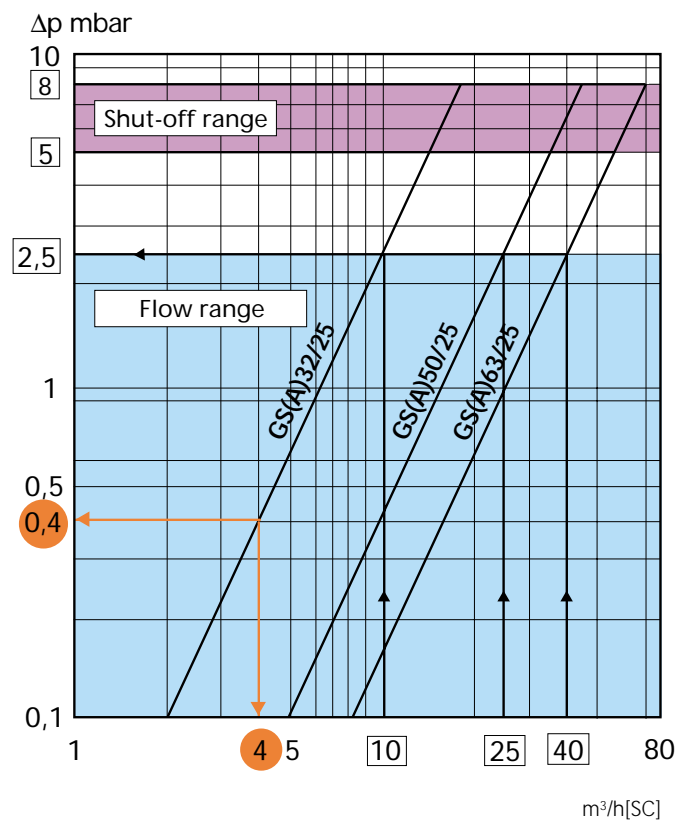



## Operating Pressure Range 150mbar – 5bar



**GS25/150, GSA25/150**  
Ø 25/DN 20

**GS32/150, GSA32/150**  
Ø 32/DN 25

### Flow Data

Operating pressure (p <sub>o</sub> ) bar	V <sub>n</sub> m <sup>3</sup> /h[SC] at p <sub>o</sub>
0,15	10
0,30	10
0,50	11
1,0	13
2,0	16
3,0	19
4,0	21
5,0	23

### Flow Data

Operating pressure (p <sub>o</sub> ) bar	V <sub>n</sub> m <sup>3</sup> /h[SC] at p <sub>o</sub>
0,15	22
0,30	23
0,50	25
1,0	29
2,0	35
3,0	41
4,0	46
5,0	50

### Flow Diagram

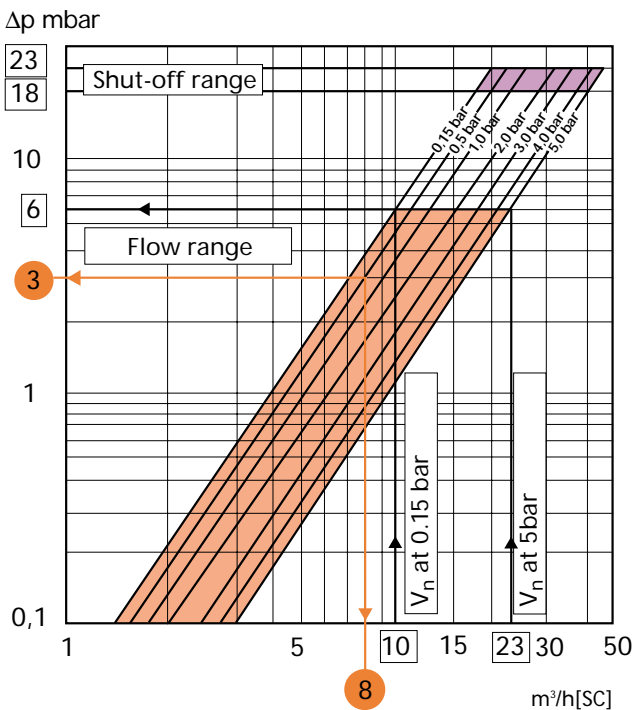

**Example:** → ●  
Operating pressure: 0.5bar V<sub>n</sub> = 8m<sup>3</sup>/h[SC] Δp = 3mbar

### Flow Diagram

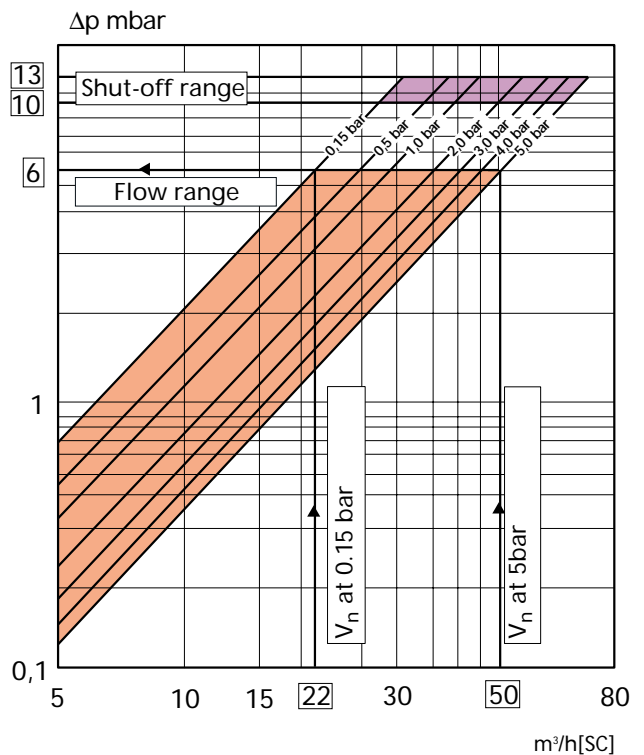

**Note:** Nominal flow is dependent on the network's operating pressure. When determining the Gas-Stop type (nominal diameter), the minimum network pressure should be taken as a basis.

150mbar – 5bar



## Operating Pressure Range 150mbar – 5bar



**GS50/150, GSA50/150**  
Ø 50/DN 40

**GS63/150, GSA63/150**  
Ø 63/DN 50

### Flow Data

Operating pressure (p <sub>e</sub> ) bar	V <sub>n</sub> m <sup>3</sup> /h[SC] at p <sub>e</sub>
0,15	57
0,30	60
0,50	65
1,0	75
2,0	92
3,0	106
4,0	120
5,0	132

### Flow Data

Operating pressure (p <sub>e</sub> ) bar	V <sub>n</sub> m <sup>3</sup> /h[SC] at p <sub>e</sub>
0,15	85
0,30	90
0,50	97
1,0	112
2,0	137
3,0	159
4,0	180
5,0	200

### Flow Diagram

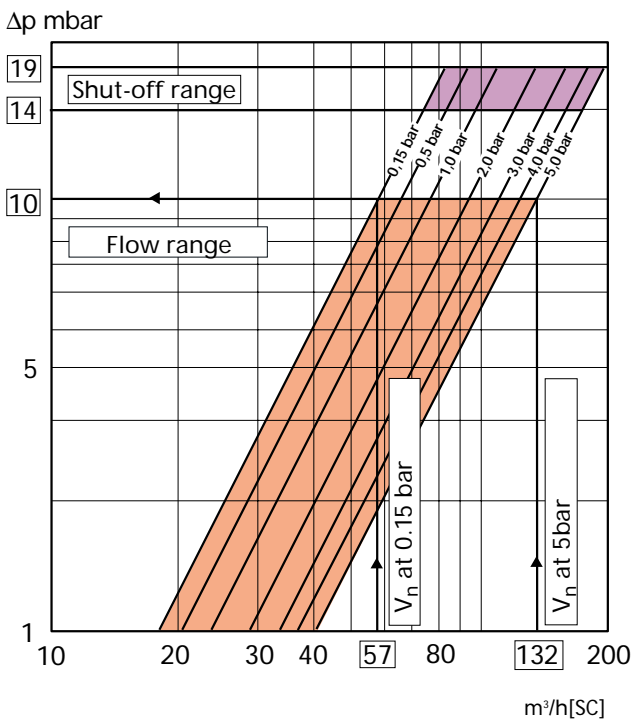

### Flow Diagram

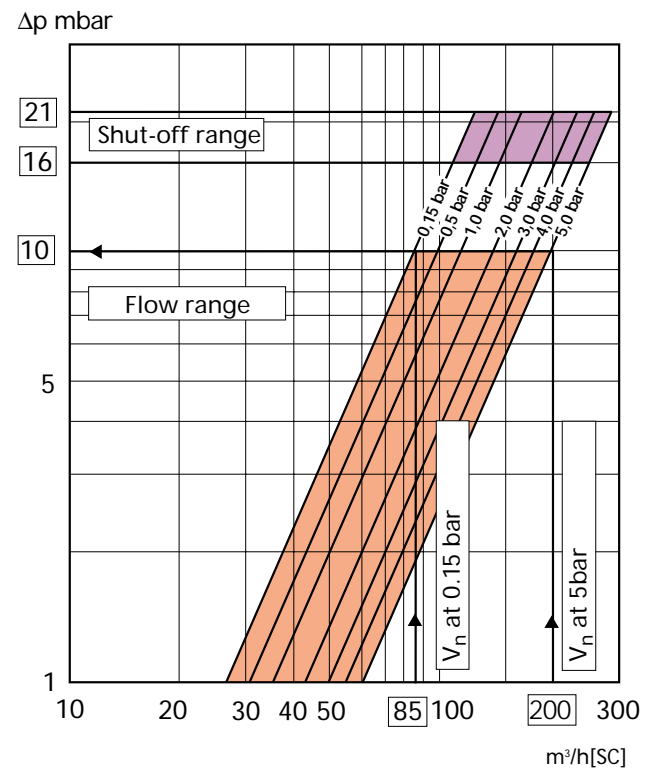

150mbar – 5bar

**Note:** Nominal flow is dependent on the network's operating pressure. When determining the Gas-Stop type (nominal diameter), the minimum network pressure should be taken as a basis.



## Operating Pressure Range 1 – 5bar



GS20/1, GSA20/1  
Ø 20/DN 15

GS32/1, GSA32/1  
Ø 32/DN 25

### Flow data

Meter size	$V_n$ m <sup>3</sup> /h[SC] at 1–5bar
G16	25

### Flow Data

Meter size	$V_n$ m <sup>3</sup> /h[SC] at 1–5bar
G65	100

### Flow Diagram

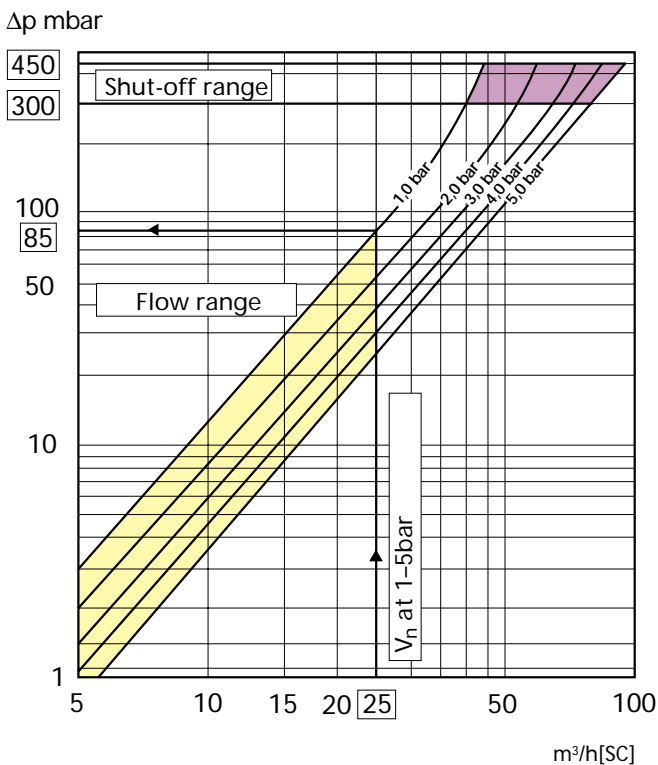

### Flow Diagram

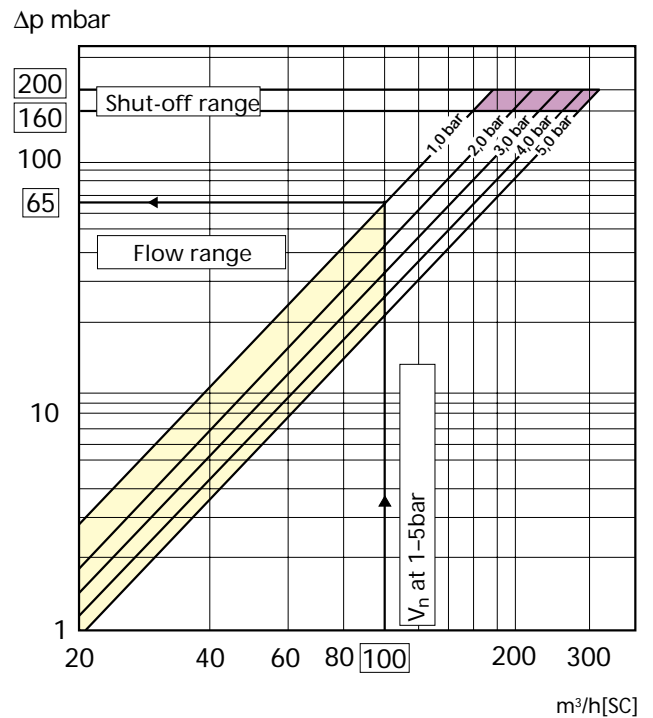

1 – 5bar

**Note:** Nominal flow is dependent on the network's operating pressure. When determining the Gas-Stop type (nominal diameter), the minimum network pressure should be taken as a basis. The minimum functional pressure required for activation of shut-off is 0.9 bar.



## Operating Pressure Range 1 – 5bar

GS63/1, GSA63/1 –Ø 63/DN 50

### Flow Data

Operating pressure ( $p_e$ ) bar	$V_n$ m <sup>3</sup> /h[SC] at $p_e$
1,0	160
2,0	200
3,0	230
4,0	260
5,0	280

### Flow Diagram

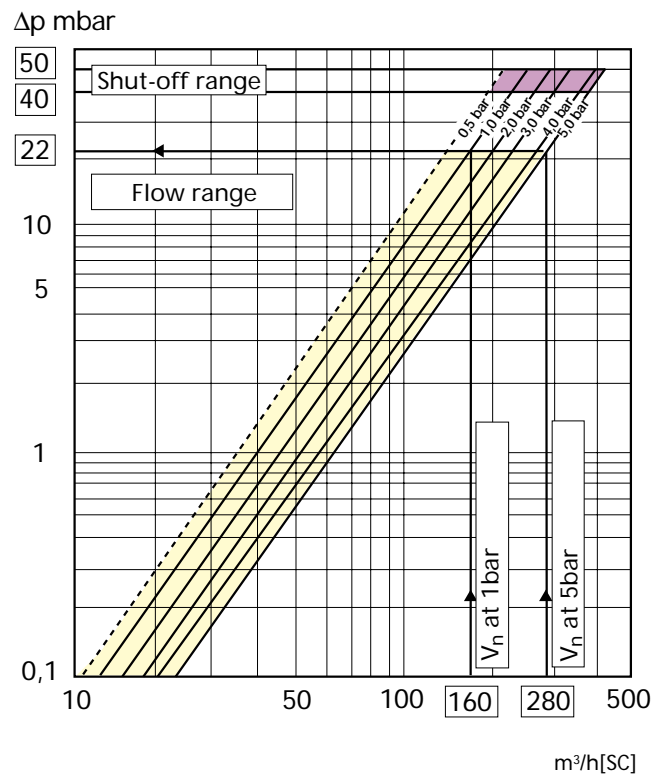

**Note:** Nominal flow is dependent on the network's operating pressure. When determining the Gas-Stop type (nominal diameter), the minimum network pressure should be taken as a basis.



**Operating Pressure Range 300mbar – 5bar**  
GS63/300, GSA63/300 – Ø 63/DN 50

## Pipelife Gas-Stop for main lines

Testen and proven for use in networks

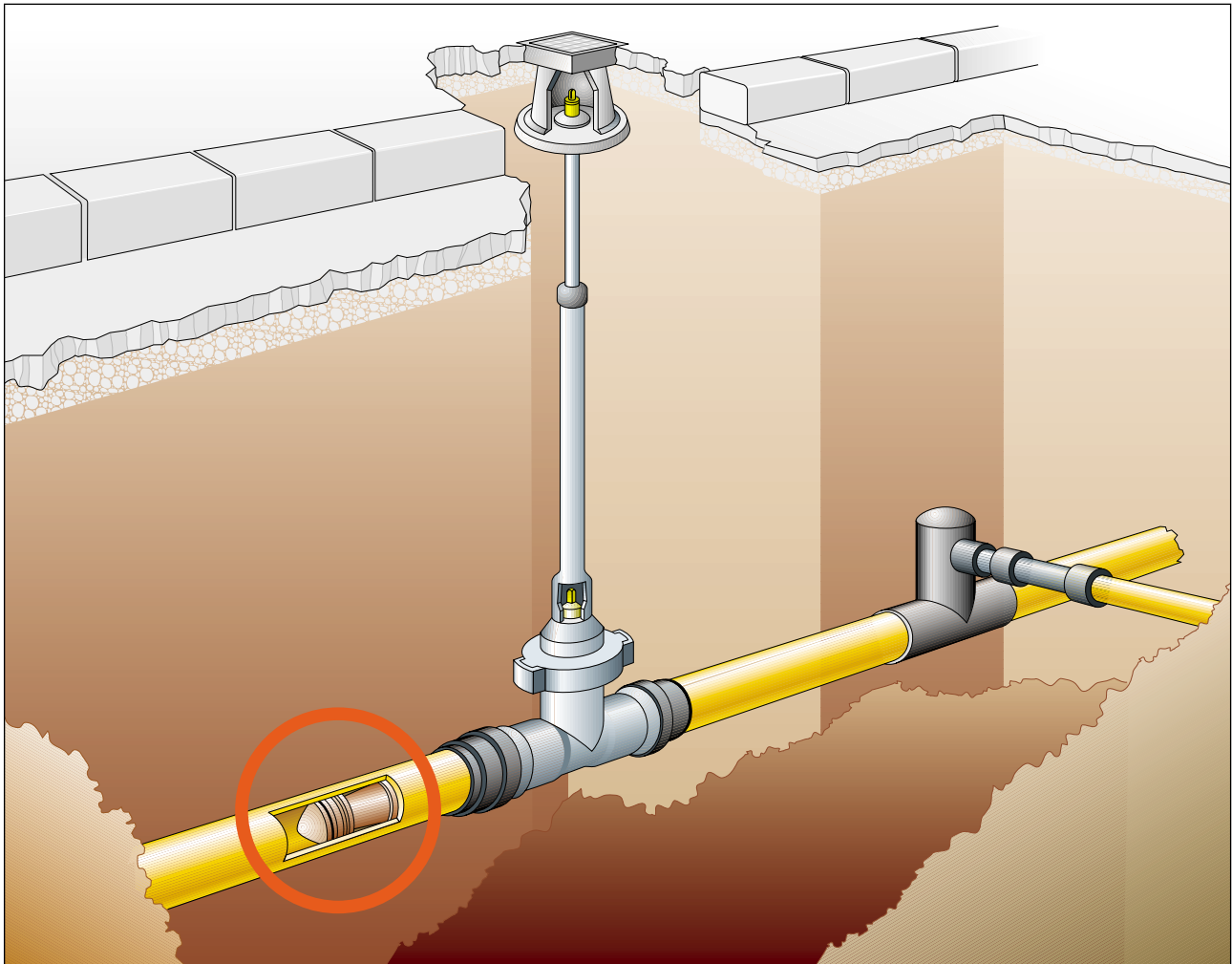

*Pipelife Gas-Stop for main lines have been in use in networks since 1997.*

In recent years, networks have been installed with operating pressures up to 4 and 5 bar, particularly in the regional gas supply sector. The trend in this direction is increasing strongly, as such systems bring significant cost savings when compared to systems in the  $\leq 100$ mbar pressure range.

For instance, one of the techniques is to supply regions with multiple local supplies from a single PE transport line (e.g. Ø160/DN150). PE pipes with dimensions of Ø63/DN50 are primarily used as main lines in the individual local supplies (see Installation and Connection Diagram on page 15). The high operating pressures in these networks also mean that very large quantities of gas escape in the event of damage to one of these main lines, which can represent a significant safety hazard.



## Operating Pressure Range 300mbar – 5bar GS63/300, GSA63/300 – Ø63/DN 50

The demand for a Pipelife Gas-Stop which can be employed in main lines came from the gas supply companies which make use of this technique. In 1996, the further development of the proven Pipelife Gas-Stop technology to comply with the requirements of the gas supply companies was begun. In the very same year, the initial preliminary series entered the test phase. Since 1997, Pipelife Gas-Stops for main lines are produced in series.

Experiences to date show that the products are absolutely safe for operation and function according to specifications in the event of damage. The development of additional dimensions is planned.

### Installation and Connection Diagram Local Distribution $p_{\max} = 4\text{bar}$ with Pipelife Gas-Stop for main lines and service lines

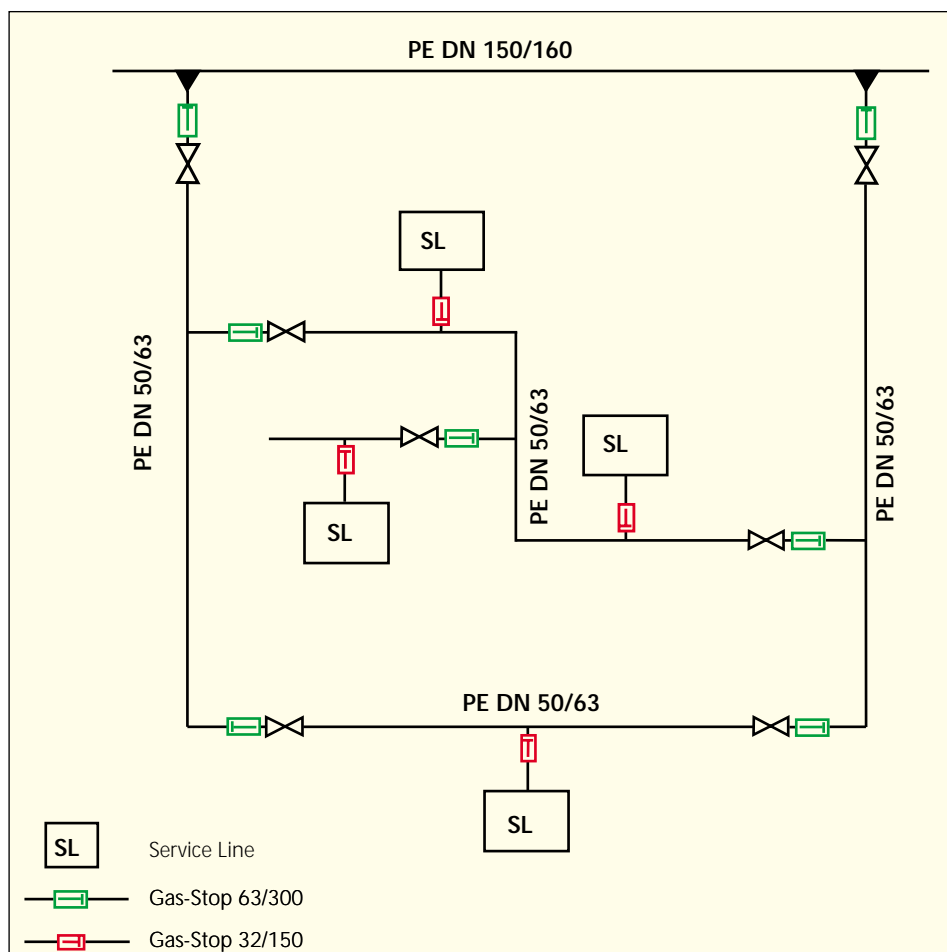



## Operating Pressure Range 300mbar – 5bar GS63/300, GSA63/300 – Ø 63/DN 50

Pipelife Gas-Stop unit for installation in main lines. It contains an integrated overflow device. The maximum overflow volume is approximately 0.7 m<sup>3</sup>/h. For line lengths greater than 100 meters after the Pipelife Gas-Stop units, we recommend installation of a sleeve valve immediately after the Pipelife Gas-Stop unit (see Installation and Connection Diagram on page 15). By closing this armature, pressure equalization is carried out in a few seconds. Refilling the line can be effected over a short period of time by slowly opening the sleeve valve.

### Flow Data

Operating pressure (p <sub>e</sub> ) bar	V <sub>n</sub> m <sup>3</sup> /h[SC] at p <sub>e</sub>
0,3	200
1,0	250
2,0	300
3,0	350
4,0	400
5,0	428

### Flow Diagram

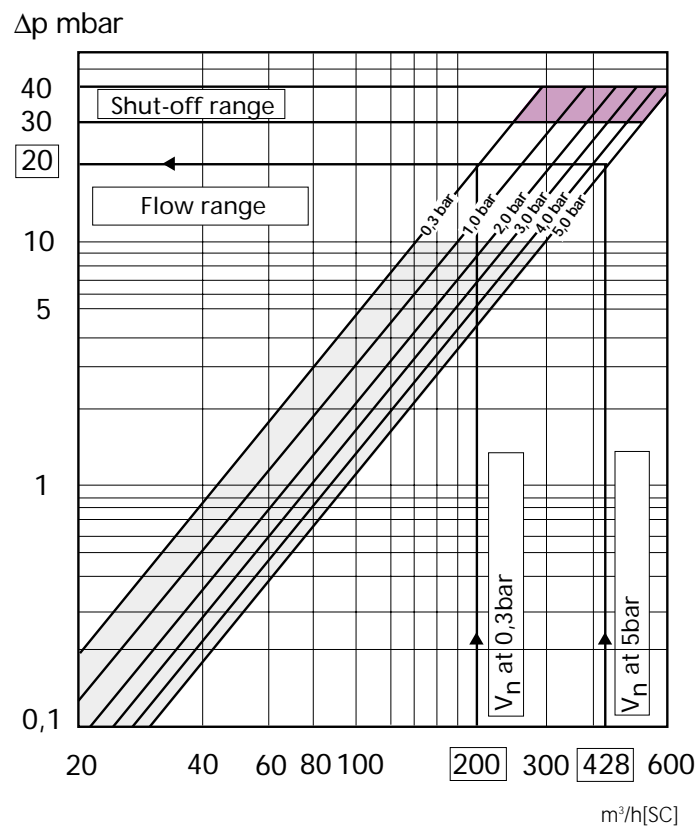

# Installation Instructions

## Pipeline Gas-Stop Type GS and GSA Series

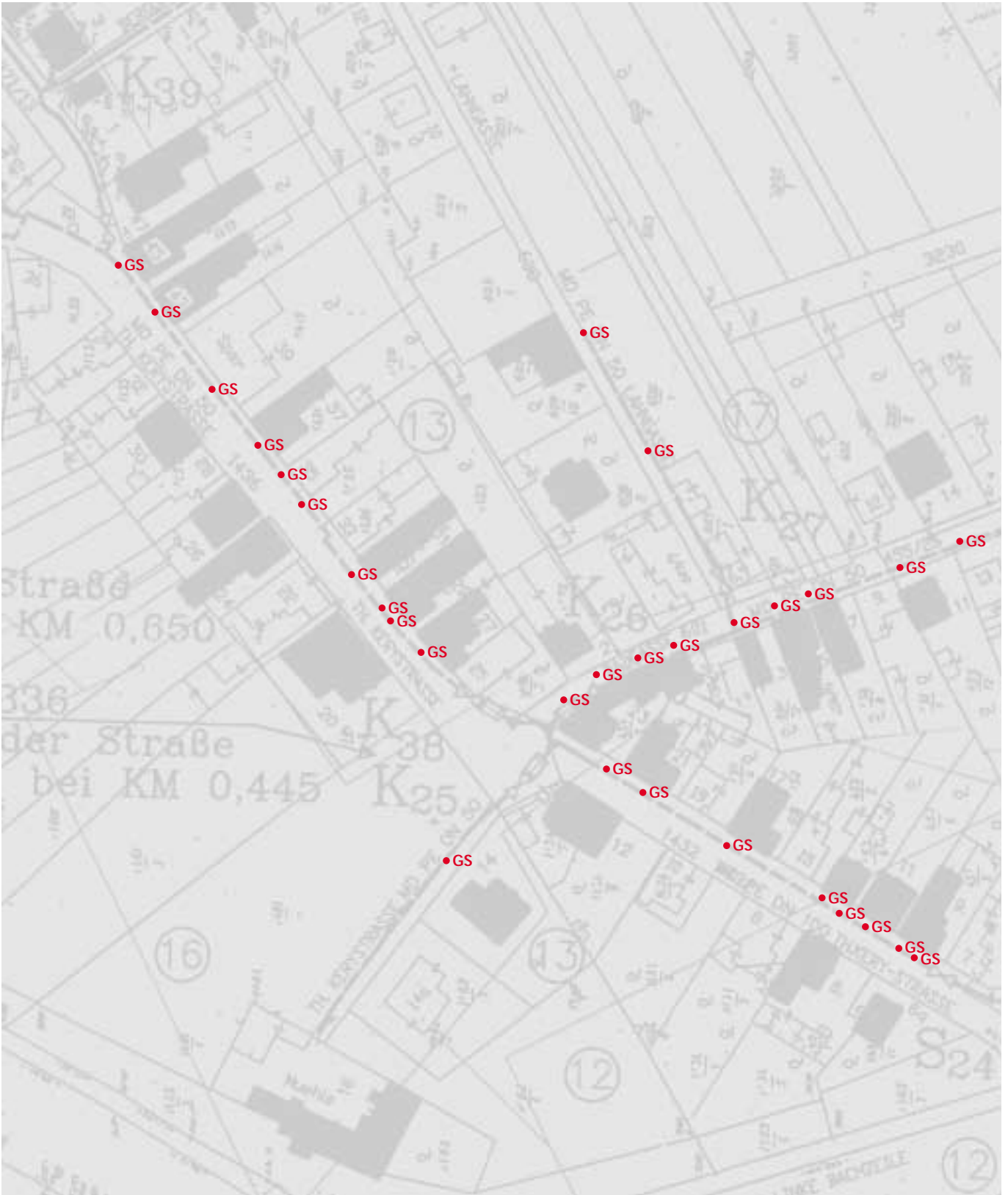

# General Information



## Type GS Series:

This type of Pipelife Gas-Stop can be inserted in the output of compatible tapping saddles\* (Diagrams 1+2). In order to facilitate full insertion, the lip ring can be moistened. An additional sticker with the serial number is included with each Pipelife Gas-Stop. Recommendation: Attach this sticker to an appropriate place on the tapping saddle - see also Point 2 of the Section "Prior to Installation".

\*We can provide you with the names of suitable manufacturers on request.

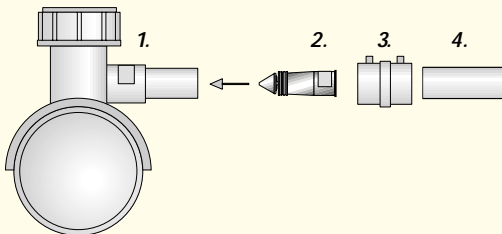

Dia. 1

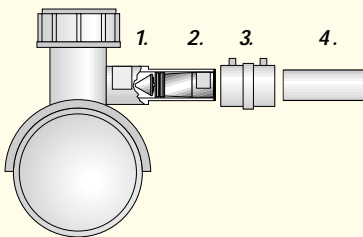

Dia. 2

## Type GSA Series:

The Pipelife Gas-Stop is integrated into a pipe section (adapter made of PE 80\*), see Diagrams 3 and 4. Standard commercial electrofusion couplers are used for installation into the line system. A sticker with the serial number is found on the adapter as well as on the integrated Pipelife Gas-Stop unit itself.

\* PE 100 upon request

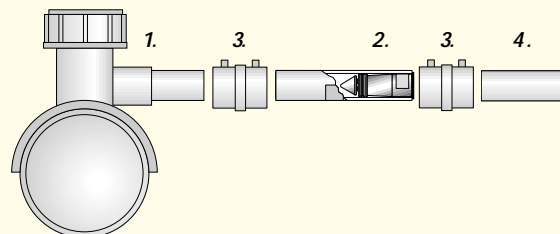

Dia. 3

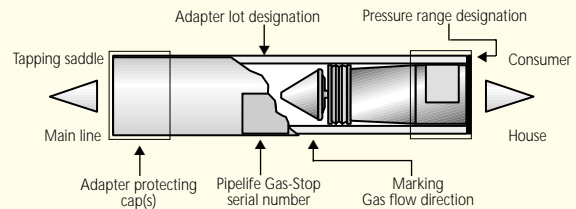

Dia. 4

1. Tapping saddle
2. Pipelife Gas-Stop type GS (Dia. 1+2) and GSA (Dia. 3)
3. Electrofusion coupler(s)
4. PE service line

---

## Prior to Installation

1. Check to see if the colour of the sticker with the serial number matches the planned operating pressure. You can find the nominal flow values and the  $\Delta p$  guidelines in the Technical Specification sheets, see pages 8-16.

<b>GREEN</b>	<b>= 15 – 100mbar</b>
<b>BLUE</b>	<b>= 25 – 100mbar*</b>
<b>RED</b>	<b>= 150mbar – 5bar**</b>
<b>YELLOW</b>	<b>= 1 – 5bar</b>
<b>WHITE</b>	<b>= 300mbar – 5bar</b>

\* DVGW-type A    \*\*DVGW-type B (-4bar)

2. **Recommendation:** Note the serial number of the Pipelife Gas-Stop unit in the line installation records or on the installation diagrams for the household line.
3. **Marking - Pressure range for Gas-Stop type (GS and GSA):** see Diagram 4 on page 18. Check that the marking is correct for the planned operating pressure.

**Preparation of the tapping saddle outlet (Type GS):** Follow the instructions provided by the manufacturer.

**Preparation of the welding ends of the adapter (Type GSA):** Clean the welding ends of the adapter with PE cleaning agents. Scraping is not necessary.

## Installation

For tapping saddles, in which the Pipelife Gas-Stop unit is already installed in the outlet, the welding process can be carried out as usual. Adapters with integrated Pipelife Gas-Stop (Type GSA) can be welded into the service line system using commercial electrofusion couplers.

## Starting operation

### Operating Pressure: 15–100mbar and 25–100mbar

1. Open the main shut-off valve (MSV) approx. 30% to ventilate the line. If necessary, attach a ventilation tube to the MSV and bleed off the gas in a safe area.
2. If the Pipelife Gas-Stop now closes, the MSV was open too far. Close the MSV - the Pipelife Gas-Stop automatically opens after approx. 10 seconds to 10 minutes, depending on the length and diameter of the service line.
3. Repeat the ventilation process again with smaller openings of the MSV.
4. Close the MSV after ventilation is completed.

## Operating Pressure: 150mbar and 1– 4bar (recommandation)

1. Install a "ventilation adapter" (e.g. flange with pre-installed ventilation pipe) on the MSV.
2. Attach a ventilation tube, for example with a quick release coupler, to the ventilation pipe and run the tube to an open space.
3. Open the MSV to ventilate.
4. If the Pipelife Gas-Stop unit closes, the ventilation tube is too large. You will now have to find a suitable source of pressure, e.g. nitrogen or natural gas canister, and equalize to the network pressure in order to open the pipelife Gas-Stop unit. Repeat the ventilation process with a small diameter tube or smaller opening of the armature.
5. Close the MSV after ventilation is complete.

## Re-starting operation

Following damage to a household line in the Pipelife Gas-Stop closes. Repair of the household line can now be effected, **while taking a relevant and necessary safety pre-cautions**. After completion of repairs, operation of the line can be restarted according to usual work procedures.

## Installation with reduction pieces

By using appropriate reduction pieces, it is possible to use the Pipelife Gas-Stop for the next smallest nominal diameter in all pressure ranges  $\geq 150\text{mbar}$  (Dia. 5 and 6).

We would be happy to provide information regarding reduction possibilities in the  $\leq 100\text{mbar}$  pressure range.

When using a Pipelife Gas-Stop unit for pipelines of the next largest dimension, an adapter must be used to prevent axial displacement of the Pipelife Gas-Stop.

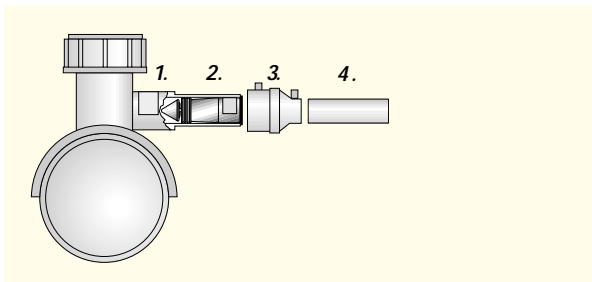

Dia. 5

1. Tapping saddle with output  $\text{Ø}50/\text{DN}40$
2. Pipelife Gas-Stop type GS50 (Dia. 5) or type GSA50 (Dia. 6)
3. Electrofusion reducer da50 to da40
4. PE service line  $\text{Ø}40/\text{DN}32$

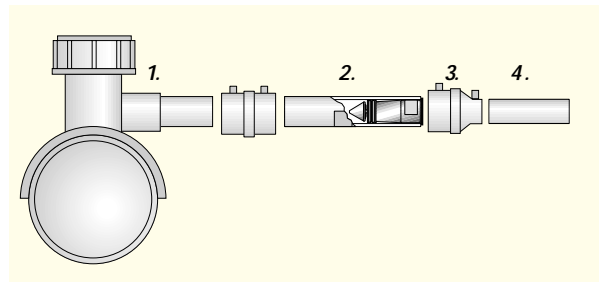

Dia. 6

**Example:** The Gas-Stop type GS50 or GSA50 can be also used with a reduction piece for a service line  $\text{Ø}40/\text{DN}32$ .

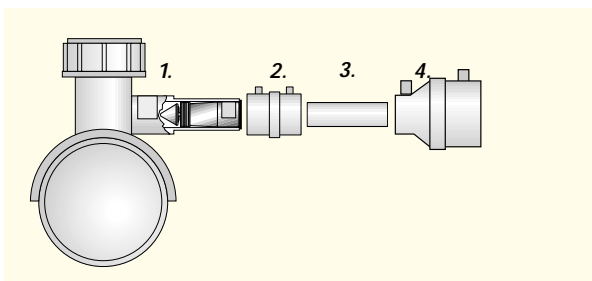

Dia. 7

1. Tapping saddle with output  $\text{Ø}32/\text{DN}25$  and installed Gas-Stop
2. Electrofusion coupler
3. Pipe section  $\text{Ø}32/\text{DN}25$
4. Electrofusion reducer from  $\text{Ø}32/\text{DN}25$  to  $\text{Ø}40/\text{DN}32$

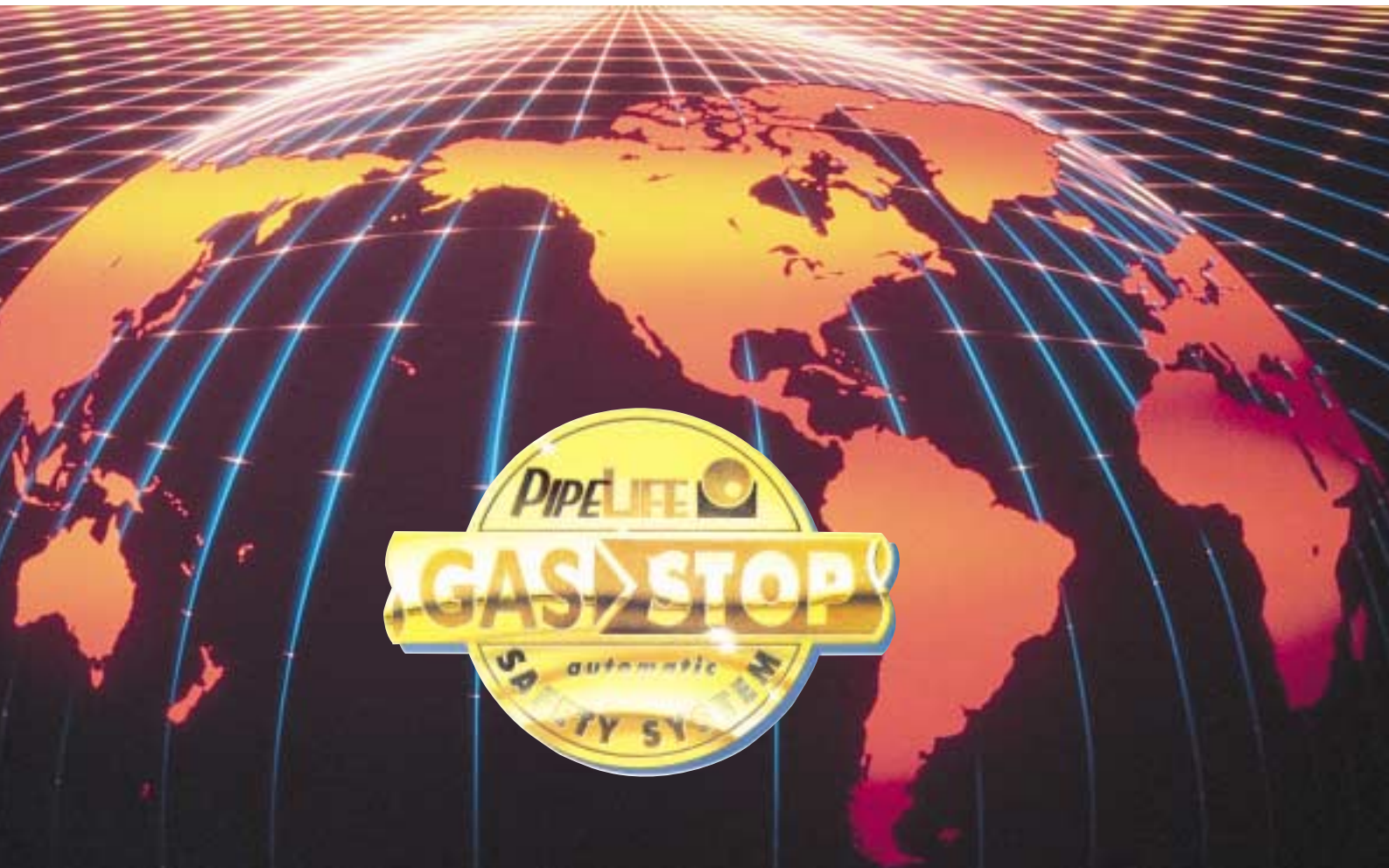

Pipelife Austria GmbH & Co KG  
IZ NÖ-Süd, Straße 1, Objekt 27  
A-2355 Wiener Neudorf - Austria  
Tel.: +43 (0) 2236 6702-281 or 680  
Fax: +43 (0) 2236 6702-264 or 670  
E-mail: [gasstop@pipelife.at](mailto:gasstop@pipelife.at)  
Internet: [www.pipelife.at](http://www.pipelife.at)

